



[www.scanninglens.com](http://www.scanninglens.com)

## Model FT-100 F-Theta Scan Lens for 1064nm Applications

### GEOMATEC Brand Scanning Lenses

Designed for High Performance Laser System Applications based on 1064, 532 and 355nm Wavelengths, GEOMATEC Scanning Lenses offer the laser system integrator superior performance, high quality and excellent uniformity from unit to unit, in one of the smallest packages found in the industry. GEOMATEC high quality coatings and meticulous manufacturing and quality standards produce a highly reliable unit you can depend on for your laser system.

### Model # FT-100 F-Theta Scan Lens for 1064nm Applications



Model #	FT-100
Wavelength:	1064nm
Focal Length:	101.3mm
Scanning Area:	80mm $\phi$
Entrance Pupil:	12mm $\phi$
Spot Size:	17 $\mu$ m $\phi$
Scan Angle:	+/-22.68°
Mechanical Back:	107.5mm
Transmittance:	$\geq$ 95%

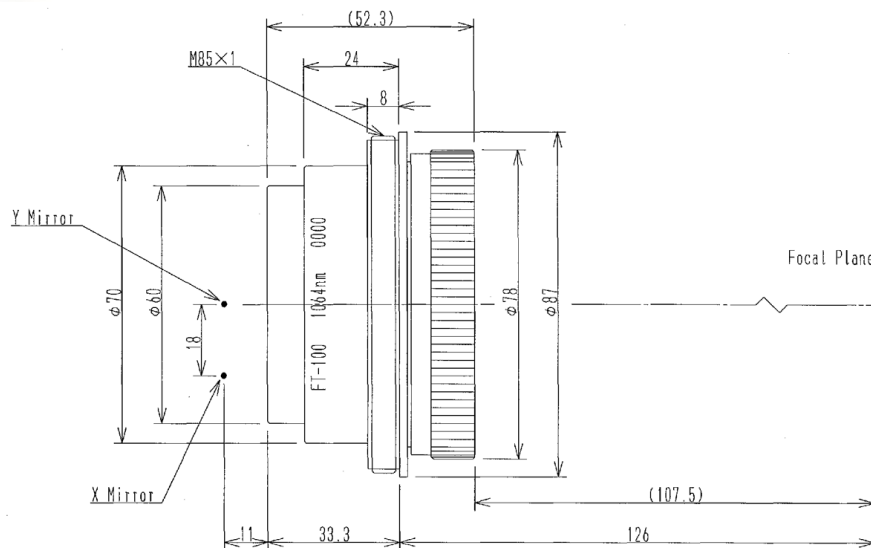

All dimensions in millimeters unless specified otherwise, specifications subject to change without notice.

[scanninglens.com](http://scanninglens.com) is owned and operated by:  
 Bay Photonics, Canton, MA, 02021 Tel: 781-255-1064